

Take Flight

1. On paper about 8 inches by 2 1/2 inches, draw a shape like the picture and cut it out.*
2. Cut along the center line.*
3. Fold along the dotted line so that one rotor bends forward the other backward.
4. Push a paper clip onto the other end of the paper.
5. Drop your helicopter from a height and watch how it spins.
6. Bend the rotors the other way. In which direction does the helicopter spin now?
7. Drop you helicopter upside down. Will it turn the right way up again?

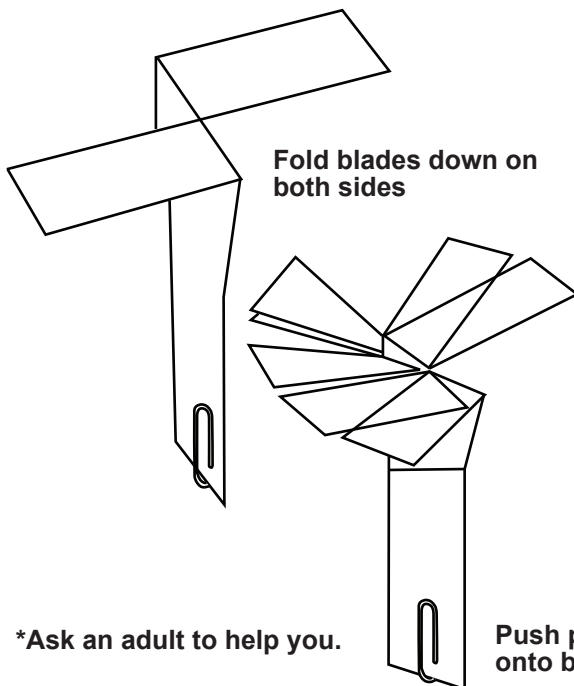

*Ask an adult to help you.

Push paper clip onto bottom

Fold Back

Fold Forward

Cut Along Here



hightouch hightech®

Science Made Fun!